

Plan View

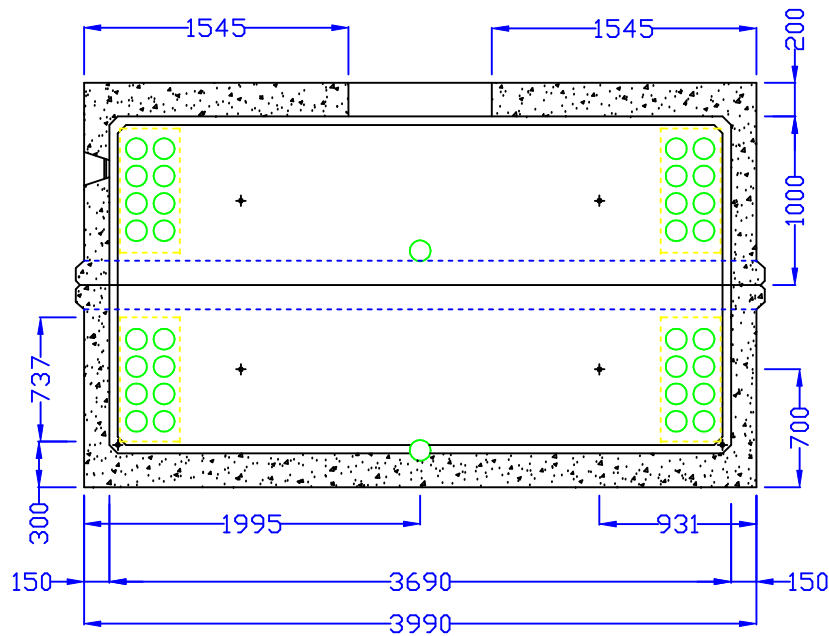

Section A-A

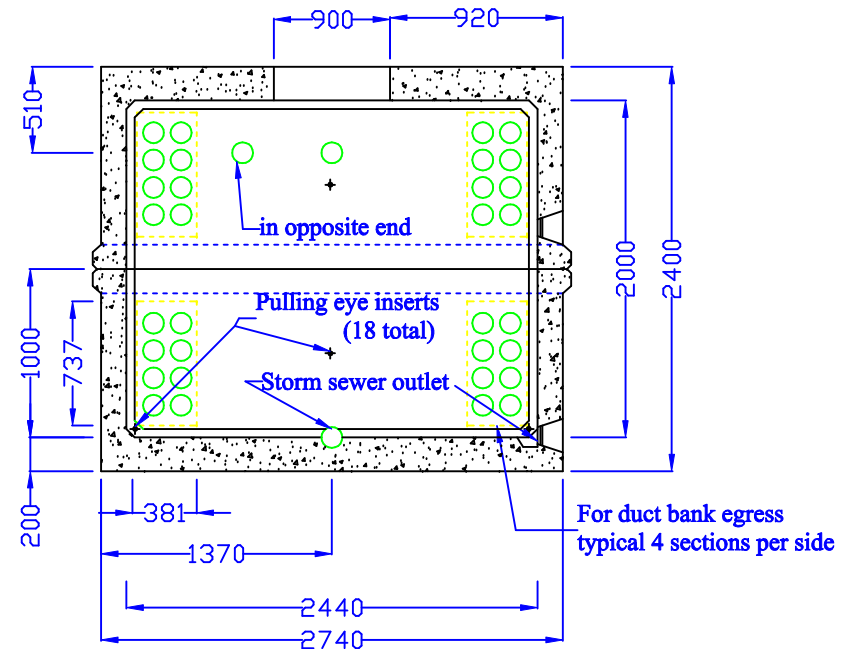

Section B-B

Notes:

1. Concrete 35 mpa - Air 6-7%
  2. Unit reinforced for H-20 loading.
  3. Duct openings are recessed from outside & flush with interior wall. 125mm Polyloc Pipe Seals are used to seal duct.
  4. Openings in top can be moved or resized.
  5. Joint between bottom and top sealed with butyl sealant. (supplied)
  6. Weight of each half - 11,000 kg.
  7. Unit will be set by Acton Precast truck provided site conditions allow.
- \* all dim. in mm. \*

Acton Precast Concrete Limited

tel 1-800-461-1516

fax 519-853-1324

8-12 Electrical Manhole